

316L STAINLESS STEEL FITTINGS



SPECIFICATION:

Fluid	Air,Water,Steam
Operating Pressure	0-1.5MPa
Max Pressure	1.8MPa
Operating Temperature	- 20°C~140°C

Features

- 1、 The materials ensure anti-corrosion highly, all of them are made from SUS316L except the seal ring.
- 2、 FKM is used as the seal ring, which can ensure anti-corrosion and acid resistant, also can be used in high temperature.
- 3、 The accessories reach the Food Hygiene Law of People's Republic of China, which are widely used in the range of industry such as food, chemical, medical, lithium and other industries.

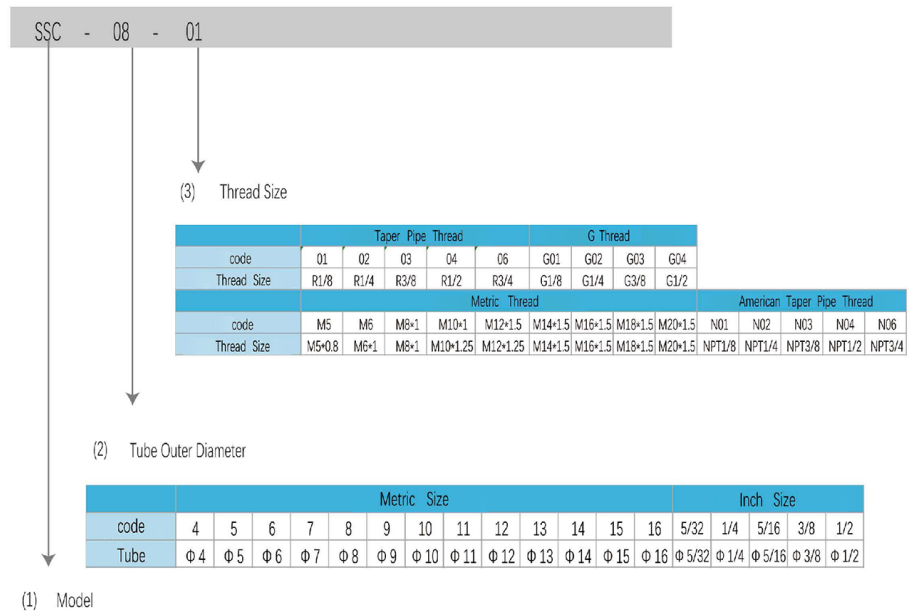

316L STAINLESS STEEL FITTINGS

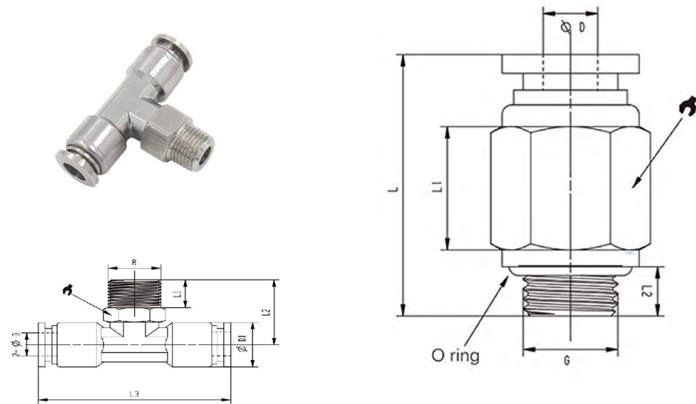

MODEL	Φ D	R	L1	L2	L3	Φ DI	↻
SSB04 -M5	4	M5	4	21.5	37	10	10
SSB04 -01	4	R1/8	7.5	21.5	37	10	12
SSB04 -02	4	R1/4	9.5	24	37	10	14
SSB06 -M5	6	M5	4	22.5	40.5	12	10
SSB06 -01	6	R1/8	7.5	22.5	40.5	12	12
SSB06 -02	6	R1/4	9.5	24.5	40.5	12	14
SSB06 -03	6	R3/8	10.5	25	40.5	12	17
SSB08 -01	8	R1/8	7.5	23.5	43	14	12
SSB08 -02	8	R1/4	9.5	26	43	14	14
SSB08 -03	8	R3/8	10.5	26.5	43	14	17
SSB08 -04	8	R1/2	13.5	33	43	14	21
SSB10 -01	10	R1/8	7.5	28.5	55	17	14
SSB10 -02	10	R1/4	9.5	28.5	55	17	14
SSB10 -03	10	R3/8	10.5	28.5	55	17	17
SSB10 -04	10	R1/2	13.5	36.5	55	17	21
SSB12 -02	12	R1/4	9.5	30	61	20	14
SSB12 -03	12	R3/8	10.5	30	61	20	17
SSB12 -04	12	R1/2	13.5	36.5	61	20	21

The Attention of Using the Quick Connecting Tube Fitting

The Structure of the Quick Connecting Tube Fittings

When installing the tube into the quick connecting tube fitting, use the tube cutter to make a straight 90 degree cut. Tube should be pushed into the fitting completely past the packing, allowing the lock claws to fully retain the tube in place. If this is not done, leakage may occur. For removal of the tube, press the sleeve to recess the lock claws, then pull out the tube.

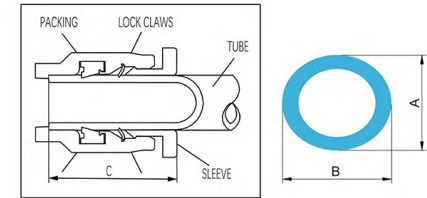

Depth of Assembling tube with Fitting

TubeSize	Standard Type						Compact Type				Standard Type					
	φ 4	φ 6	φ 8	φ 10	φ 12	φ 14	φ 16	φ 3	φ 4	φ 6	φ 5/32	φ 3/16	φ 1/4	φ 5/16	φ 3/8	φ 1/2
A	10.5	12.5	14	17	20.5	22	24	6.5	8	10	10.5	10.5	12.5	14	17	20.5
B	12	14	16	19.5	23	24.5	27	7.5	10	12	12	12	14	16	19.5	23

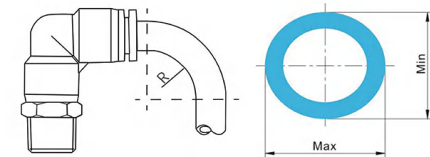

Tube has a tolerance, which is shown in table 3 and ellipticity of within 0.2mm (between Max and Min diameter) is allowed for the tube. The tube must not be bent excessively near the joint. For installation of the tube, use the recommendation below.

The Radius of Curvature for Tubing per Size

TubeSize	Standard Type						Compact Type				Standard Type					
	φ 4	φ 6	φ 8	φ 10	φ 12	φ 14	φ 16	φ 3	φ 4	φ 6	φ 5/32	φ 3/16	φ 1/4	φ 5/16	φ 3/8	φ 1/2
R	20	30	50	80	150	230	350	15	20	30	20	25	30	50	80	150

WARNING

- Never use for fluids other than air and water (Water: available in case of special type only)
- Never use at the place of spatter to avoid fire
- Be sure to use with Rotary Joint to prevent damage or leakage at the place of rotation
- Never use with water hotter than 60°C. This causes breakage of resin due to hydrolysis or heat

CAUTION

1. Be sure to meet the following conditions for the tube, otherwise it may cause leakage of air or inferiority of the application.

Size	Nylon Tube	Polyurethane Tube	Size	Nylon Tube	Polyurethane Tube
Ø3mm	±0.08	±0.08	Ø1/8	±0.08	±0.08
Ø4mm	±0.1	±0.1	Ø5/32	±0.1	±0.1
Ø6mm	±0.1	±0.1	Ø3/16	±0.1	±0.1
Ø8mm	±0.1	±0.1	Ø1/4	±0.1	±0.1
Ø10mm	±0.15	±0.1	Ø5/16	±0.1	±0.1
Ø12mm	±0.15	±0.1	Ø3/8	±0.15	±0.1
Ø14mm	±0.15	±0.1	Ø1/2	±0.15	±0.1
Ø16mm	±0.15	±0.1			

Table3 : ID tolerance

2. Cautions in the application of tube:
- (1) Be sure to confirm that the section of tube is cut at a right angle. Make sure that there is no indication of damage to the outside of the tube
 - (2) Be sure to confirm that the tube is inserted into the packing, in order to sure no leakage
 - (3) Be sure to confirm that the tube won't be pulled out after the tube inserted
3. Cautions on disconnecting tube:
- (1) Before disconnecting tube, be sure to confirm that the pressure inside the tube is at 0. And Pull it out after pressing the sleeve equally on both sides Unequal pressing strength will make scratch on tube by insufficient open of lock claws, this will cause air leakage
 - (2) Be sre not to shake or make 360 degree rotation when disconnecting the tube. The scratch made by the misuses will cause air leakage
4. Cautions on treatment of the equipment body:
- (1) When fastening the body onto the six-angle part of the inside and outside of the fitting. Choose the correct tool and size
 - (2) When fastening the thread, please refer to the specified torque range(Detail catalog). If torque is higher than the recommended, this may cause damage or air leakage. If torque is lower than the recommended, this may cause air leakage
 - (3) After fastening the Quick Connecting Tube Fitting, the direction of it won't be changed. If adjusting, please refer to the range of the torque
5. Cautions on disconnecting the equipment body
- (1) When disconnecting the body onto the six-angle part of the inside and outside of the fitting. Choose the correct tool and size
 - (2) After disconnecting the body, please clean the thread glue on equipment, otherwise the remaining thread glue will enter the equipment and cause damage